

FINISH CODES

FILL IN SHADED AREAS TO COMPLETE THE PART DESCRIPTION

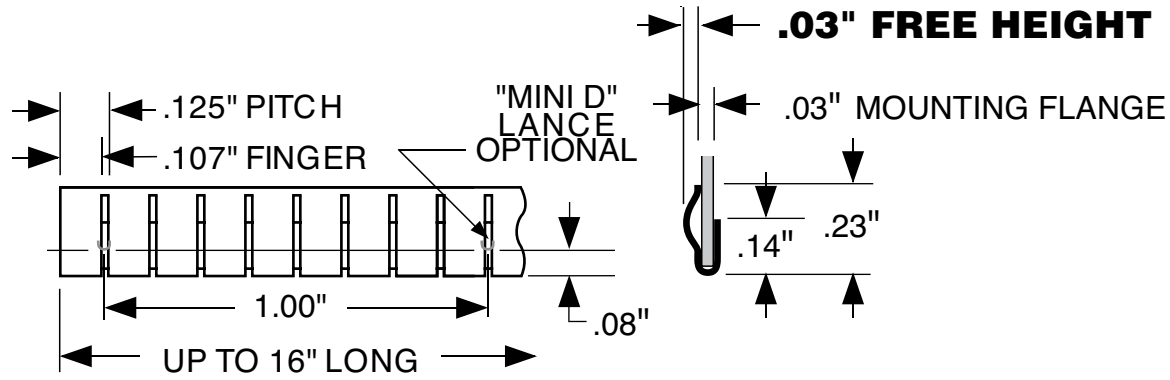

SEE NOTE 3

TECH-ETCH MANUFACTURING PART NUMBER

<p>125G23C040 - -</p> <p>(PROFILE) - (LENGTH) - (FINISH)</p>
<p>LENGTH CALCULATOR FOR PART NUMBER ABOVE</p> <p>CLICK HERE FOR STOCK LENGTH, OR ENTER NUMBER OF FINGERS HERE:</p>

NOTES:

1. MATERIAL .002 BeCu, C17200 HARDENED.
2. FINISH: AS SPECIFIED - SEE TOP LEFT.
- 3 STRIPS MAY BE SUPPLIED CUT TO ANY FULL FINGER INCREMENT.
ALLOWED LENGTHS = NUMBER OF FINGERS MINUS SLOT WIDTH.
4. UNLESS OTHERWISE SPECIFIED DIMENSIONS ARE IN INCHES.

<p>UNLESS OTHERWISE SPECIFIED ALL TOLERANCES TO BE:</p> <p>.XX ±.02 .XXX ±.005 .X ±.005/in.</p>	<p>Tech-Etch</p> <p>45 Aldrin Road, Plymouth, MA 02360 TEL 508-747-0300 • FAX 508-746-9639 sales@tech-etch.com • www.tech-etch.com</p>
<p>SCALE: 200%</p>	<p>CATALOG PROFILE: 125G23C040</p>
<p>DATE:</p>	<p>PART NAME: Clip-on Low Profile</p>
<p>CUSTOMER PART NUMBER:</p>	