

FINISH CODES

FILL IN SHADED AREAS TO COMPLETE THE PART DESCRIPTION

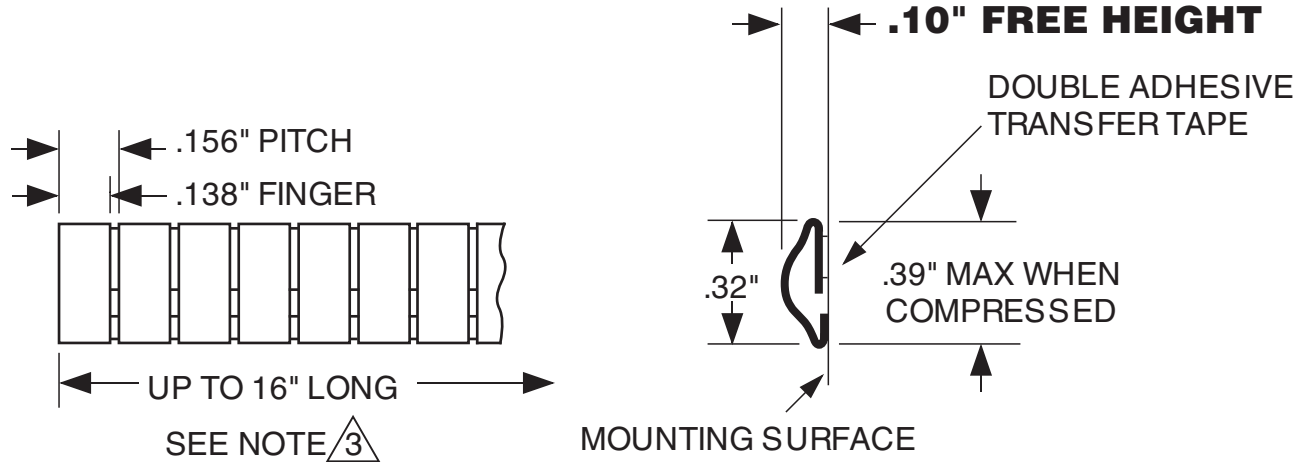

TECH-ETCH MANUFACTURING PART NUMBER

156M32 - -			
(PROFILE)	-	(LENGTH)	-
LENGTH CALCULATOR FOR PART NUMBER ABOVE			
CLICK HERE FOR STOCK LENGTH, OR ENTER NUMBER OF FINGERS HERE:			

NOTES:

1. MATERIAL \varnothing 035" BeCu, C17200 HARDENED.
2. FINISH: AS SPECIFIED - SEE TOP LEFT.
3. STRIPS MAY BE SUPPLIED CUT TO ANY FULL FINGER INCREMENT. ALLOWED LENGTHS = NUMBER OF FINGERS MINUS SLOT WIDTH.
4. UNLESS OTHERWISE SPECIFIED DIMENSIONS ARE IN INCHES.

UNLESS OTHERWISE SPECIFIED ALL TOLERANCES TO BE: .XX \pm .02 .XXX \pm .005 .X \pm .005/in.	 45 Aldrin Road, Plymouth, MA 02360 TEL 508-747-0300 • FAX 508-746-9639 sales@tech-etch.com • www.tech-etch.com
SCALE: 200%	CATALOG PROFILE: 156M32
DATE: 5/1/03	PART NAME: Stick-on No-Snag Fingers
CUSTOMER PART NUMBER:	