

FINISH CODES

FILL IN SHADED AREAS TO COMPLETE THE PART DESCRIPTION

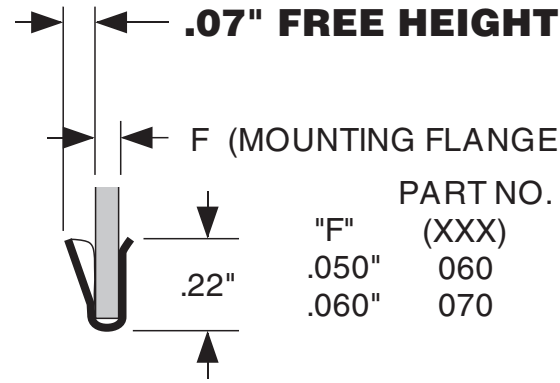
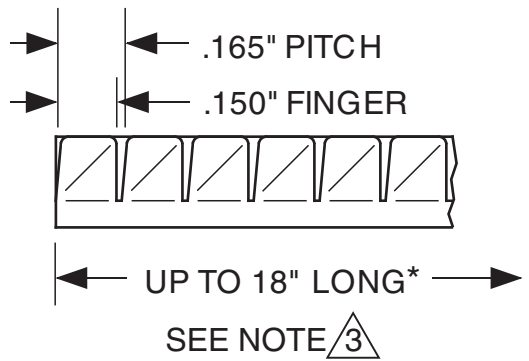

	PART NO.
"F" (XXX)	(XXX)
.050"	060
.060"	070

*Consult factory for longer lengths.

TECH-ETCH MANUFACTURING PART NUMBER

165TC	M	-	-
(PROFILE)		(LENGTH)	(FINISH)
LENGTH CALCULATOR FOR PART NUMBER ABOVE			
CLICK HERE FOR STOCK LENGTH,			
OR ENTER NUMBER OF FINGERS HERE:			

NOTES:

1. MATERIAL ~~Al-10%Ni~~ Cu, C17200 HARDENED.
2. FINISH: AS SPECIFIED - SEE TOP LEFT.
- 3 STRIPS MAY BE SUPPLIED CUT TO ANY FULL FINGER INCREMENT. ALLOWED LENGTHS = NUMBER OF FINGERS MINUS SLOT WIDTH.
4. UNLESS OTHERWISE SPECIFIED DIMENSIONS ARE IN INCHES.

UNLESS OTHERWISE SPECIFIED ALL TOLERANCES TO BE: .XX ±.02 .XXX ±.005 .X ±.005/in.	 45 Aldrin Road, Plymouth, MA 02360 TEL 508-747-0300 • FAX 508-746-9639 sales@tech-etch.com • www.tech-etch.com
SCALE: 200%	
DATE: 5/1/03	PART NAME: Clip-on Twisted Contacts
CUSTOMER PART NUMBER:	