

**FINISH CODES**

**FILL IN SHADED AREAS TO COMPLETE THE PART DESCRIPTION**

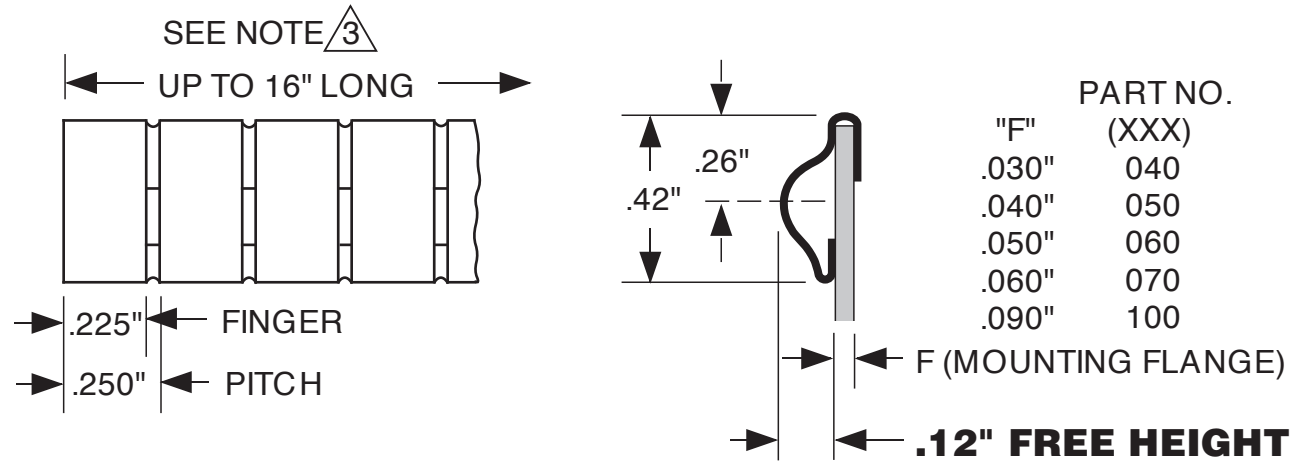

**TECH-ETCH MANUFACTURING PART NUMBER**

250M42C	-	-
(PROFILE)	(LENGTH)	(FINISH)
CHOOSE STANDARD THICKNESS OR "TF" THICKNESS		
<b>LENGTH CALCULATOR FOR PART NUMBER ABOVE</b>		
CLICK HERE FOR STOCK LENGTH, OR ENTER NUMBER OF FINGERS HERE:		

**NOTES:**

1. MATERIAL .0035" BeCu, C17200 HARDENED.
2. FINISH: AS SPECIFIED - SEE TOP LEFT.
3. STRIPS MAY BE SUPPLIED CUT TO ANY FULL FINGER INCREMENT. ALLOWED LENGTHS = NUMBER OF FINGERS MINUS SLOT WIDTH.
4. UNLESS OTHERWISE SPECIFIED DIMENSIONS ARE IN INCHES.

UNLESS OTHERWISE SPECIFIED ALL TOLERANCES TO BE: .XX ±.02 .XXX ±.005 .X ±.005/in.	<b>Tech-Etch</b> 45 Aldrin Road, Plymouth, MA 02360 TEL 508-747-0300 • FAX 508-746-9639 sales@tech-etch.com • www.tech-etch.com
SCALE: <b>200%</b>	CATALOG PROFILE: <b>250M42CXXX</b>
DATE: <b>5/20/09</b>	PART NAME: <b>Clip-on No-snap Fingers</b>
CUSTOMER PART NUMBER:	