

FINISH CODES

FILL IN SHADED AREAS TO COMPLETE THE PART DESCRIPTION

← .282" PITCH
← .250" FINGER

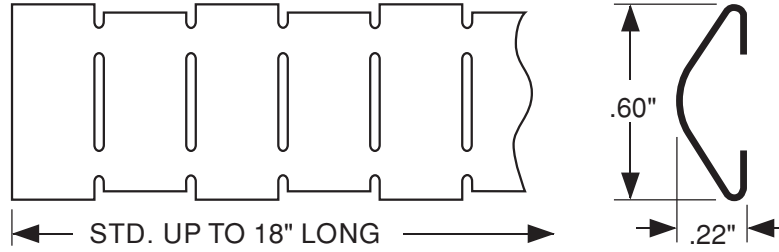

← .060" - .070"
FLANGE
(CONSULT
FACTORY
FOR OTHER
FLANGE SIZES)

← .15" (APPROXIMATE
FREE HEIGHT
WHEN INSTALLED
WITH .520"
SLOT SPACING
ON .070" FLANGE)

SELECT FINGER PATTERN DESIRED

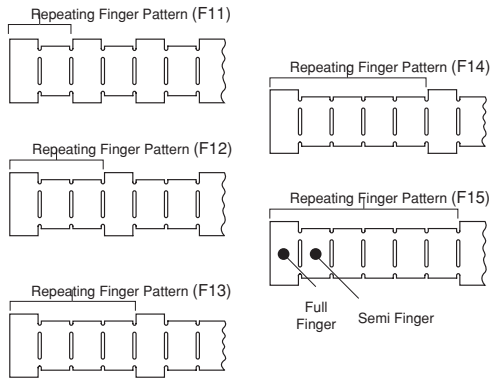

SEE NOTE ³ "TF" UP TO 24" LONG
REPEATING FINGER PATTERN F11 SHOWN

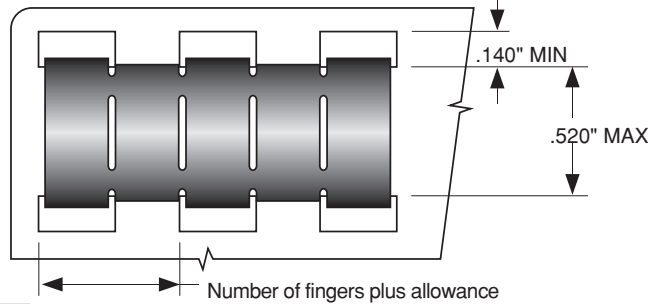

TECH-ETCH MANUFACTURING PART NUMBER

282V60F	-	-
(PROFILE)	(LENGTH)	(FINISH)
CHOOSE STANDARD THICKNESS OR "TF" THICKNESS		
LENGTH CALCULATOR FOR PART NUMBER ABOVE		
CLICK HERE FOR "TF" STD. STOCK LENGTH,		
OR ENTER NUMBER OF FINGERS HERE:		

NOTES:

- MATERIAL .005" BeCu, C17200 HARDENED.
- FINISH: AS SPECIFIED - SEE TOP LEFT.
- ³ STRIPS MAY BE SUPPLIED CUT TO ANY FULL FINGER INCREMENT.
ALLOWED LENGTHS = NUMBER OF FINGERS MINUS SLOT WIDTH.
- UNLESS OTHERWISE SPECIFIED DIMENSIONS ARE IN INCHES.

UNLESS OTHERWISE SPECIFIED ALL TOLERANCES TO BE:

.XX ±.02
.XXX ±.005
.X ±.005/in.

Tech-Etch

45 Aldrin Road, Plymouth, MA 02360
TEL 508-747-0300 • FAX 508-746-9639
sales@tech-etich.com • www.tech-etich.com

SCALE: 170%

CATALOG PROFILE: 282V60F

DATE: 1/29/04s

PART NAME: Snap-on Symmetrical Slot Mounting

CUSTOMER PART NUMBER: