

FINISH CODES

FILL IN SHADED AREAS TO COMPLETE THE PART DESCRIPTION

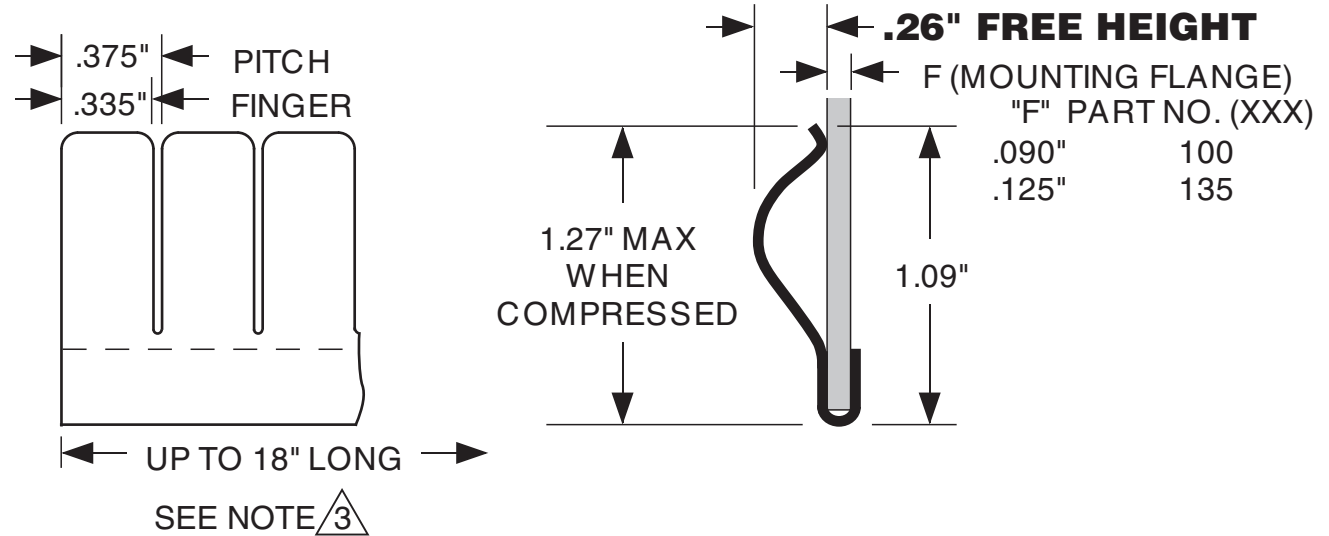

TECH-ETCH MANUFACTURING PART NUMBER

375C	-	-
(PROFILE)	(LENGTH)	(FINISH)
LENGTH CALCULATOR FOR PART NUMBER ABOVE		
CLICK HERE FOR STOCK LENGTH,		
OR ENTER NUMBER OF FINGERS HERE:		

NOTES:

- MATERIAL: ~~Al~~ ~~304~~ ~~SS~~ Cu, C17200 HARDENED.
- FINISH: AS SPECIFIED - SEE TOP LEFT.
- STRIPS MAY BE SUPPLIED CUT TO ANY FULL FINGER INCREMENT. ALLOWED LENGTHS = NUMBER OF FINGERS MINUS SLOT WIDTH.
- UNLESS OTHERWISE SPECIFIED DIMENSIONS ARE IN INCHES.

UNLESS OTHERWISE SPECIFIED ALL TOLERANCES TO BE: .XX ±.02 .XXX ±.005 .X ±.005/in.	Tech-Etch 45 Aldrin Road, Plymouth, MA 02360 TEL 508-747-0300 • FAX 508-746-9639 sales@tech-etch.com • www.tech-etch.com
SCALE: 145%	CATALOG PROFILE: 375C
DATE: 5/1/03	PART NAME: Clip-on Strip Gaskets
CUSTOMER PART NUMBER:	