

FINISH CODES

FILL IN SHADED AREAS TO COMPLETE THE PART DESCRIPTION

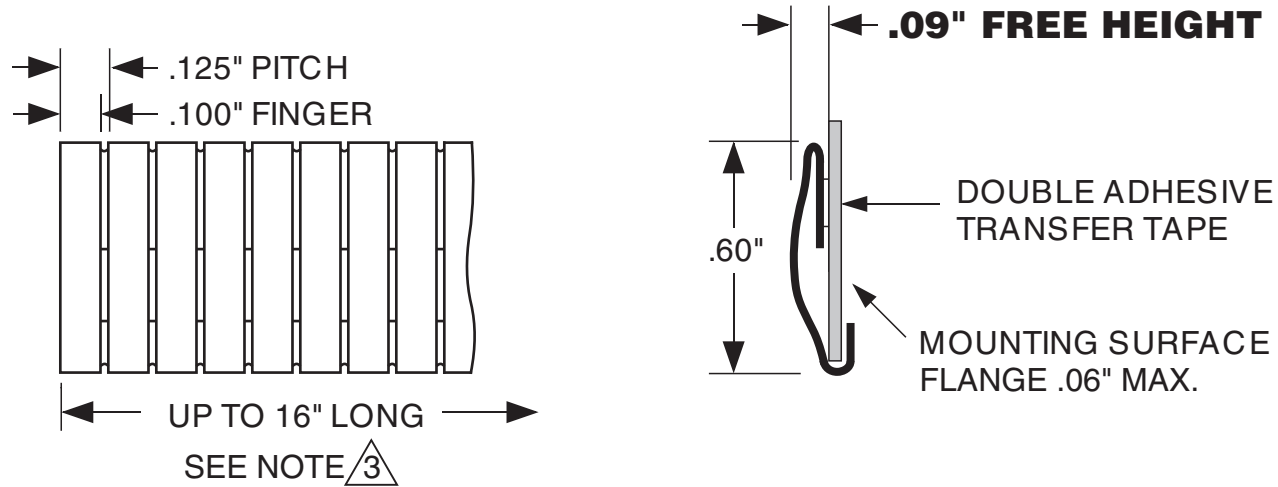

TECH-ETCH MANUFACTURING PART NUMBER

SS125LP60H060 - -			
(PROFILE)	-	(LENGTH)	- (FINISH)
LENGTH CALCULATOR FOR PART NUMBER ABOVE			
CLICK HERE FOR STOCK LENGTH, OR ENTER NUMBER OF FINGERS HERE:			

NOTES:

1. MATERIAL: ~~AISI 304~~ 301 STAINLESS STEEL.
2. FINISH: AS SPECIFIED - SEE TOP LEFT.
3. STRIPS MAY BE SUPPLIED CUT TO ANY FULL FINGER INCREMENT. ALLOWED LENGTHS = NUMBER OF FINGERS MINUS SLOT WIDTH.
4. UNLESS OTHERWISE SPECIFIED DIMENSIONS ARE IN INCHES.

UNLESS OTHERWISE SPECIFIED ALL TOLERANCES TO BE: .XX ±.02 .XXX ±.005 .X ±.005/in.	 45 Aldrin Road, Plymouth, MA 02360 TEL 508-747-0300 • FAX 508-746-9639 sales@tech-etich.com • www.tech-etich.com
SCALE: 200%	
DATE: 5/1/03	PART NAME: Hook & Stick-on Low Profile No-Snag
CUSTOMER PART NUMBER:	