

FINISH CODES

FILL IN SHADED AREAS TO COMPLETE THE PART DESCRIPTION

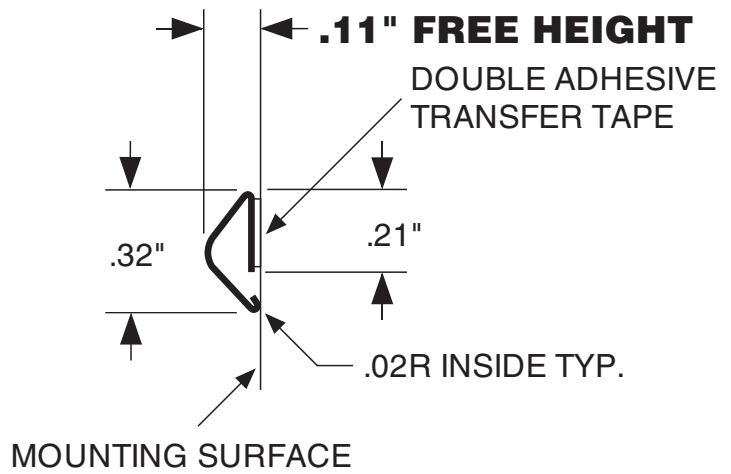
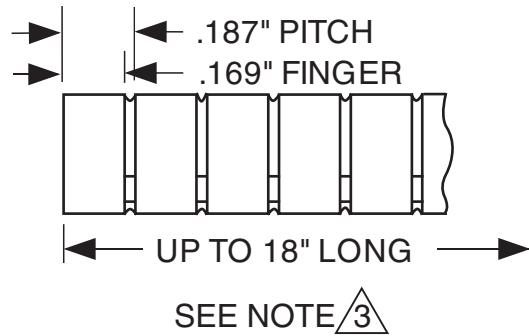

TECH-ETCH MANUFACTURING PART NUMBER

SS187P32 - -			
(PROFILE)	-	(LENGTH)	- (FINISH)
LENGTH CALCULATOR FOR PART NUMBER ABOVE			
CLICK HERE FOR STOCK LENGTH,			
OR ENTER NUMBER OF FINGERS HERE:			

NOTES:

1. MATERIAL .002" 301 STAINLESS STEEL.
2. FINISH: AS SPECIFIED - SEE TOP LEFT.
3. STRIPS MAY BE SUPPLIED CUT TO ANY FULL FINGER INCREMENT. ALLOWED LENGTHS = NUMBER OF FINGERS MINUS SLOT WIDTH.
4. UNLESS OTHERWISE SPECIFIED DIMENSIONS ARE IN INCHES.

UNLESS OTHERWISE SPECIFIED ALL TOLERANCES TO BE: .XX ±.02 .XXX ±.005 .X ±.005/in.	Tech-Etch 45 Aldrin Road, Plymouth, MA 02360 TEL 508-747-0300 • FAX 508-746-9639 sales@tech-etch.com • www.tech-etch.com
SCALE: 200%	CATALOG PROFILE: SS187P32
DATE: 5/1/03	PART NAME: Stick-on Soft No-snap Fingers
CUSTOMER PART NUMBER:	