

FINISH CODES

FILL IN SHADED AREAS TO COMPLETE THE PART DESCRIPTION

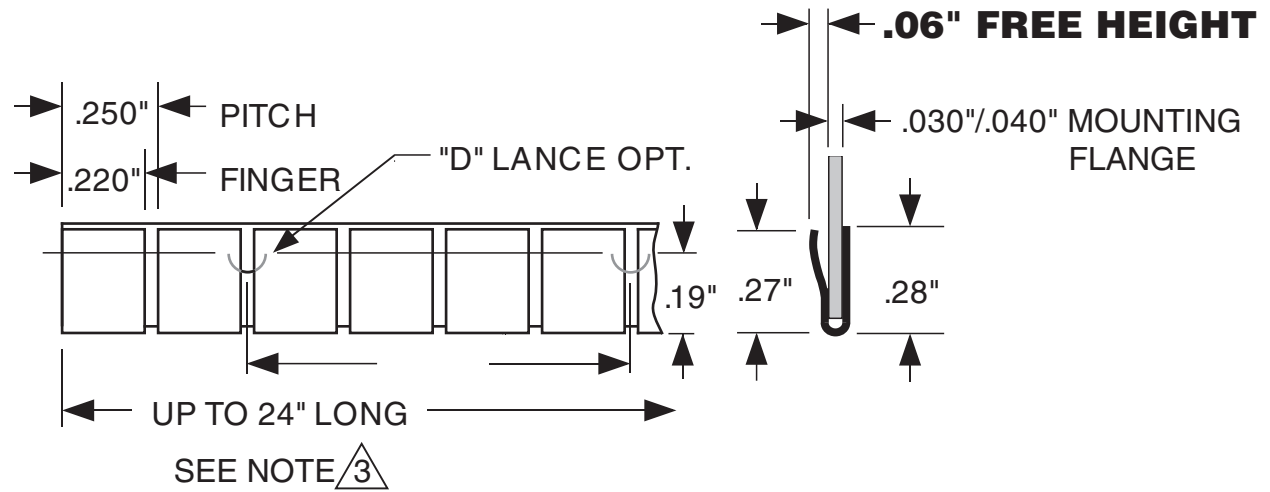

TECH-ETCH MANUFACTURING PART NUMBER

SS250C040 - - (PROFILE) - (LENGTH) - (FINISH)			
LENGTH CALCULATOR FOR PART NUMBER ABOVE CLICK HERE FOR STOCK LENGTH, OR ENTER NUMBER OF FINGERS HERE:			

NOTES:

1. MATERIAL .001 " 301 STAINLESS STEEL.
2. FINISH: AS SPECIFIED - SEE TOP LEFT.
3. STRIPS MAY BE SUPPLIED CUT TO ANY FULL FINGER INCREMENT. ALLOWED LENGTHS = NUMBER OF FINGERS MINUS SLOT WIDTH.
4. UNLESS OTHERWISE SPECIFIED DIMENSIONS ARE IN INCHES.

UNLESS OTHERWISE SPECIFIED ALL TOLERANCES TO BE: .XX ±.02 .XXX ±.005 .X ±.005/in.	<p style="text-align: center;">Tech-Etch</p> 45 Aldrin Road, Plymouth, MA 02360 TEL 508-747-0300 • FAX 508-746-9639 sales@tech-etich.com • www.tech-etich.com
SCALE: <p style="text-align: center;">200%</p>	CATALOG PROFILE: <p style="text-align: center;">SS250C040</p>
DATE: <p style="text-align: center;">5/1/03</p>	PART NAME: <p style="text-align: center;">Clip-on Low Profile</p>
CUSTOMER PART NUMBER:	