

FILL IN SHADED AREAS TO COMPLETE THE PART DESCRIPTION

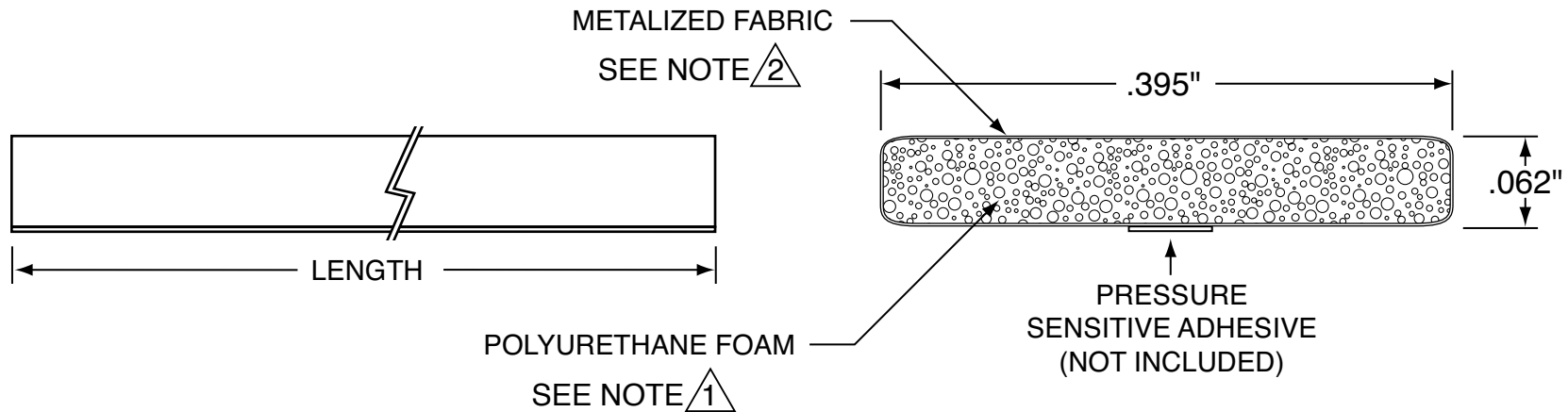

SELECT ADHESIVE MOUNTING OPTION

- WITH PRESSURE SENSITIVE ADHESIVE.
- WITHOUT PRESSURE SENSITIVE ADHESIVE.

FILL IN LENGTH IN INCHES BELOW

Fill in length to two decimals (LL.LL). Maximum 84.00 inches.
Non-essential leading zeros will be eliminated on the length.

TECH-ETCH MANUFACTURING PART NUMBER

2411 - 101 - 0231 -
 (PROFILE) - (LENGTH)

NOTES:

- ① OPEN-CELLED POLYURETHANE FOAM CORE.
- ② NICKEL PLATING OVER COPPER SUBSTRATE FABRIC.
- 3. COMPRESSION SET (ASTM D3574) 2.6%.
- 4. FLAMMABILITY RATING UL 94 V-RATED.
- 5. COMPRESSION DEFLECTION (ASTM D3574) 1.47 PSI.
- 6. SURFACE RESISTIVITY (ASTM F390) <.02 OHMS.
- 7. SERVICE TEMPERATURE -40°F TO 194°F (-40°C TO 90°C).
- 8. UNLESS OTHERWISE SPECIFIED DIMENSIONS ARE IN INCHES.

UNLESS OTHERWISE SPECIFIED ALL TOLERANCES TO BE: HEIGHT & WIDTH <.100 ±.02 >.100 ±.03 LENGTH 1 TO 6 ±.03 6 TO 11 ±.05 11 TO 24 ±.15 24+ +1/-.25	 45 Aldrin Road, Plymouth, MA 02360 TEL 508-747-0300 • FAX 508-746-9639 sales@tech-etch.com • www.tech-etch.com
SCALE: 800%	
DATE: 1/15/18	PART NAME: Rectangular Metalized Fabric Gasket
CUSTOMER PART NUMBER:	