

# HIT ENTER AS YOU FILL IN THE SHADED AREAS TO COMPLETE THE STANDARD SHIELD DESCRIPTION

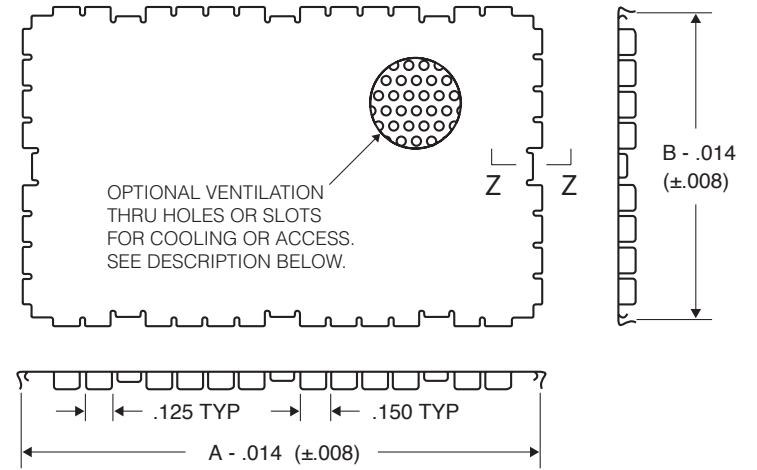
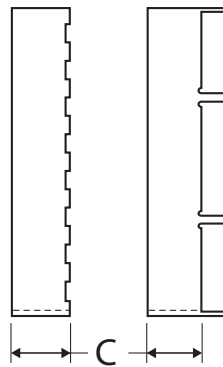
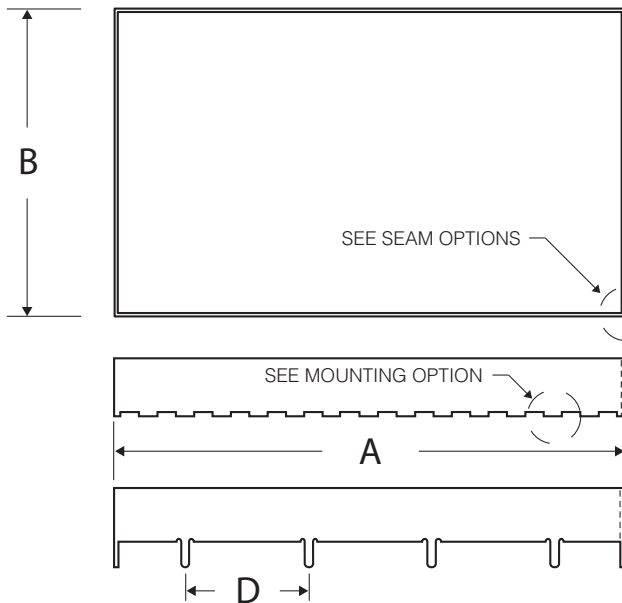

FILL IN DIMENSIONS		CLEAR
<b>DIM A</b>		
<b>DIM B</b>		
<b>DIM C</b>		
<b>DIM D</b>		
<b>DIM E</b>		
<b>DIM F</b>		

CHOOSE FINISH
Bright Tin
Matte Tin
Tin Lead

CHOOSE MATERIAL
Brass CDA 260
Steel 1010
Nickel Silver

CHOOSE MOUNTING OPTION	
<b>STANDARD SURFACE MOUNT</b> 	<b>THROUGH HOLE MOUNT</b> 

CHOOSE SEAM OPTION		
<b>NONE: NO WELD, SOLDER OR MECH. TAB</b> 	<b>WELD TAB</b> 	<b>SOLDER TAB</b> 

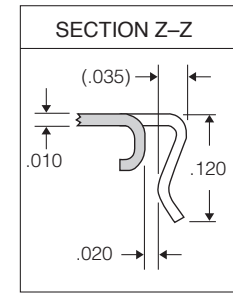

VENT OR ACCESS HOLES OR SLOTS	
NO	PLEASE DESCRIBE HERE:
YES	

DEPTH ETCHED PART NUMBER OR LOGO	
NO	PLEASE DESCRIBE HERE:
YES	

**NOTES:**

- MATERIALS: FENCE .015" 1/2 HARD BRASS, CDA 260;  
COVER .010" FULL HARD BRASS, CDA 260.
- FINISH: 200-500 MICROINCHES, BRIGHT TIN PER ASTM B-545

THIS DRAWING IS FOR STANDARD TECH ETCH BOARD LEVEL SHIELDS. OTHER CONFIGURATIONS AND OPTIONS ARE AVAILABLE. PLEASE CONTACT THE FACTORY FOR APPLICATION ASSISTANCE AND CUSTOM DESIGNS.

SUGGESTED SOURCE OF SUPPLY:  
TECH-ETCH, INC.

<b>UNLESS OTHERWISE SPECIFIED:</b> DIMENSIONS IN INCHES. TOLERANCES TO BE: .XX ±.015" .XXX ±.010" ANGLES ±3 DEG	Tech-Etch, Inc. 45 Aldrin Road Plymouth, MA 02360 TEL 508-747-0300 • FAX 508-746-9639 @techetch.com • www.techetch.com
	CUSTOMER / REF DOC:
	DESCRIPTION: <b>STD. BOARD LEVEL SHIELD - FENCE/COVER</b>
SCALE: <b>NONE</b>	CUSTOMER PART NUMBER:
DOC. REVISION DATE: <b>4/F5/21</b>	