

HIT ENTER AS YOU FILL IN THE SHADED AREAS TO COMPLETE THE STANDARD SHIELD DESCRIPTION

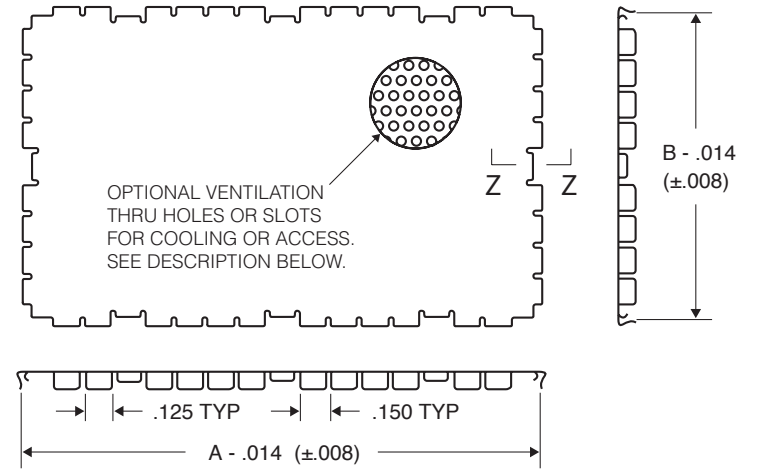
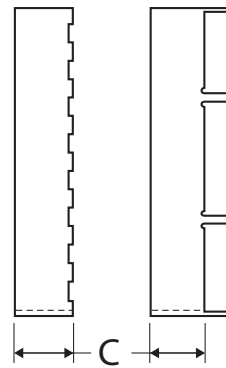
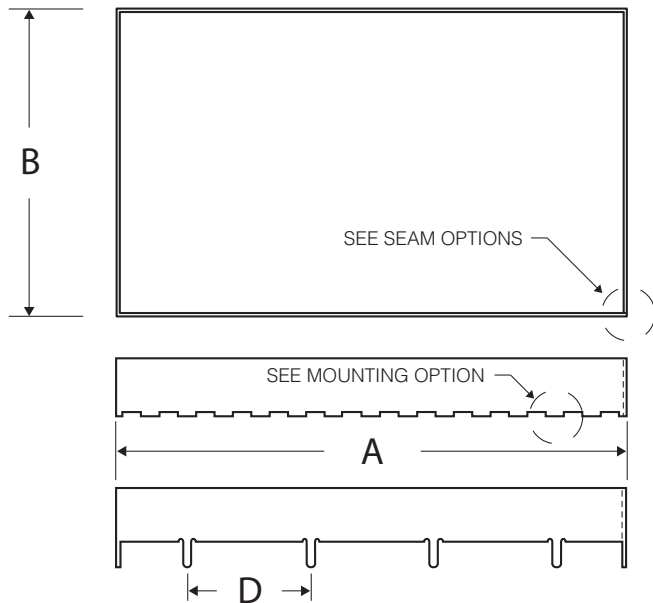

FILL IN DIMENSIONS		CLEAR
DIM A		
DIM B		
DIM C		
DIM D		
DIM E		
DIM F		

CHOOSE FINISH
Bright Tin
Matte Tin
Tin Lead

CHOOSE MATERIAL
Brass CDA 260
Steel 1010
Nickel Silver

CHOOSE MOUNTING OPTION	
STANDARD SURFACE MOUNT 	THROUGH HOLE MOUNT

CHOOSE SEAM OPTION		
NONE: NO WELD, SOLDER OR MECH. TAB 	WELD TAB 	SOLDER TAB

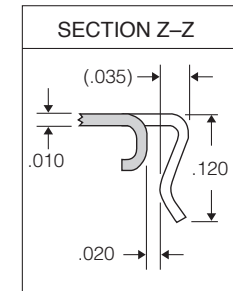

VENT OR ACCESS HOLES OR SLOTS	
NO	PLEASE DESCRIBE HERE:
YES	

DEPTH ETCHED PART NUMBER OR LOGO	
NO	PLEASE DESCRIBE HERE:
YES	

NOTES: CHOOSE FINISH B4 MATERIAL

- MATERIALS: FENCE .015" 1/2 HARD BRASS, CDA 260; COVER .010" FULL HARD BRASS, CDA 260.
- FINISH: 200 MICRONS MIN, BRIGHT TIN PER ASTM B-545
- THIS DRAWING IS FOR STANDARD TECH ETCH BOARD LEVEL SHIELDS.
- SUGGESTED SOURCE OF SUPPLY:
TECH-ETCH, INC. 45 ALDRIN ROAD PLYMOUTH, MA 02360

UNLESS OTHERWISE SPECIFIED:
 DIMENSIONS IN INCHES.
 TOLERANCES TO BE:
 .XX ±.015"
 .XXX ±.010"
 ANGLES ±3 DEG

SCALE: NONE
 DOC. REVISION DATE: 8/F5/24



Tech-Etch, Inc.
 45 Aldrin Road
 Plymouth, MA 02360
 TEL 508-747-0300 • FAX 508-746-9639
 @techetch.com • www.techetch.com

CUSTOMER / REF DOC:

DESCRIPTION:
STD. BOARD LEVEL SHIELD - FENCE/COVER

CUSTOMER PART NUMBER: